



ARDAS PACKERS

M: +91 8600869610 / +91 9172469227

W : www.ardaspackers.in | E : info@ardaspackers.in



ARDAS

P A C K E R S

Innovation in packaging



Your Identity Our
Technology



About

ARDAS PACKERS

Ardas Packers is mainly engaged in import and export of Packaging Machine and Packaging Material. Ardas Packers is always keen to provide quality product and services in the field of packaging machinery to their client. The team at Ardas Packers had experienced of about more than 8 years in this industry which results in the functionality and services of Ardas Packers. Customized packaging, quality assured range and prompt delivery are offered to our valuable customers, keeping the convenience in our mind. In a zest to attain maximum customer satisfaction, we have never compromised in our Quality Standards.

NEXUS-1000

ServoBagger with Multihead Weigher

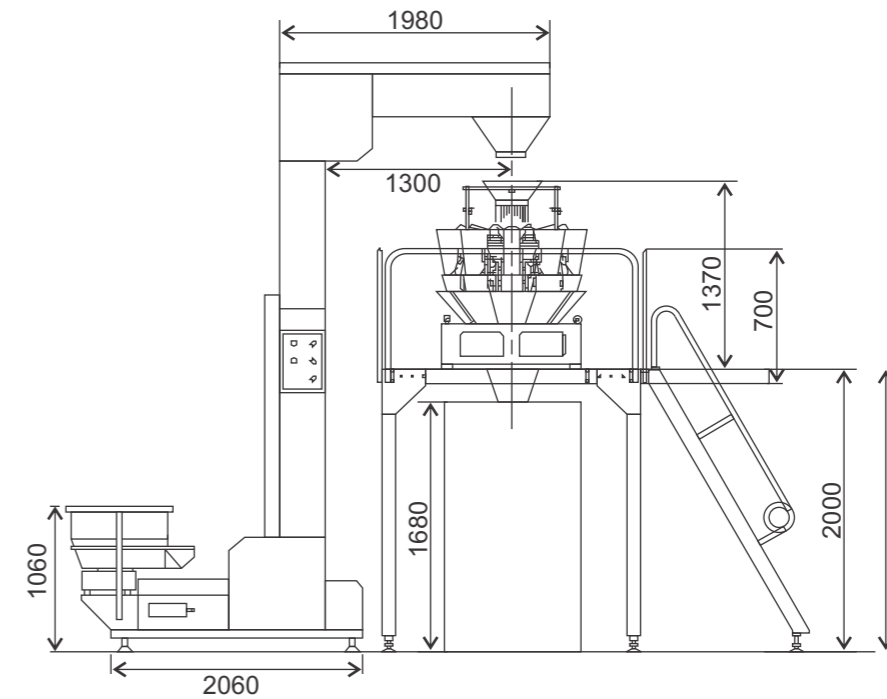

Automatic Form Fill & Seal Machine with Multihead Weigher for **Chips, Fryms, Namkeen, Snacks, Grains & Free Flow Products Like Pulses, Soya Chunks, Whole Spices, Detergent Powder, Pesticides Etc.** in Multihead Weigh Filler

Technical Specification

Packing Range	: 10gm to 1kg
Filling System	: (Multi Head Weigher) 10 Head Weigh Filler & 14 Head Weigh Filler
Filling Accuracy	: - / + 0.1%
Type of Sealing	: Center Seal
Film Size	: 100mm-500mm width x 100mm-360mm length
Film Roll Type	: Laminated Film in Roll Supported Film E.g. Aluminum Foil Pe
Speed	: 45 to 60 bag/min (Varies with the nature of product & filling range)
Power	: 3kw 230v / AC / Single Phase / 50hz
Wooden Case	: 1300mm x 1000mm x 1000mm (H x W x L)
Machine Size	: 72" x 85" x 126
Weight	: 1400kg (Approx)
Compressed Air	: 6 CFM @ 6 bar
Optional	: Batch Coding Device

NEXUS-1000

ServoBagger with Multihead Weigher

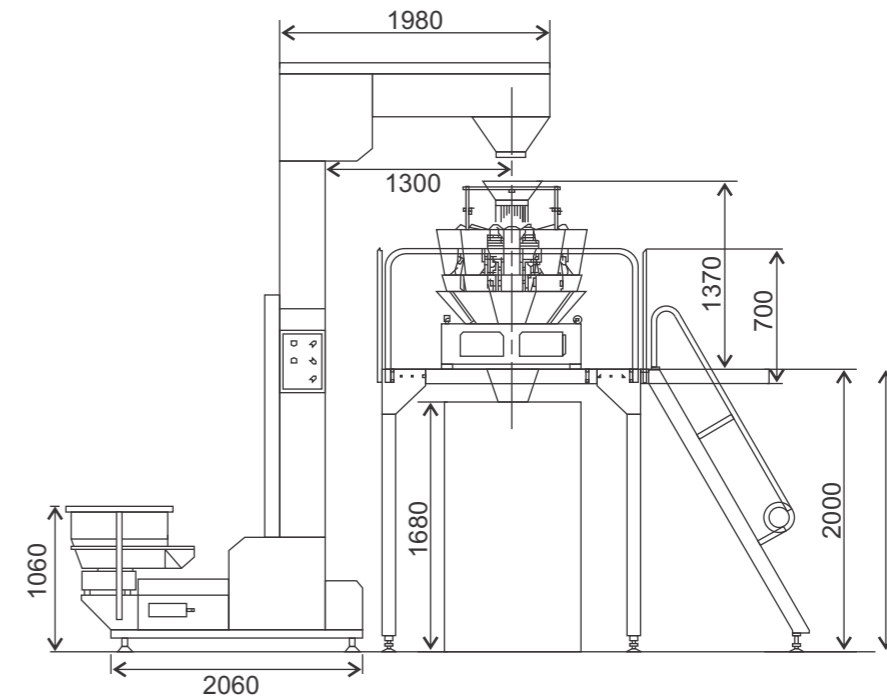

Automatic Form Fill & Seal Machine with Multihead Weigher for **Chips, Fryms, Namkeen, Snacks, Grains & Free Flow Products Like Pulses, Soya Chunks, Whole Spices, Detergent Powder, Pesticides Etc.** in Multihead Weigh Filler

Technical Specification

Packing Range	: 10gm to 100gm
Filling System	: (Multi Head Weigher) 14 Head Weigh Filler
Filling Accuracy	: - / + 0.1%
Type of Sealing	: Center Seal
Film Size	: 100mm-420mm width x 100mm-300mm length
Film Roll Type	: Laminated Film in Roll Supported Film E.g. Aluminum Foil Pe
Speed	: 60 to 90 bag/min (Varies with the nature of product & filling range)
Power	: 4.5kw 415v / AC / Three Phase / 50Hz
Wooden Case	: 1300mm x 1000mm x 1000mm (H x W x L)
Machine Size	: 72" x 85" x 126
Weight	: 1400kg (Approx)
Compressed Air	: 6 CFM @ 6 bar
Optional	: Batch Coding Device

NEXUS-500

Pneumatic Bagger with Four Head Weigher



Automatic Form Fill & Seal Machine with Four Head Weigh Filler for Grains & Free Flow Powder Products Like **Pulses, Rice, Tea, Sugar, Namkeen, Whole Spices, Detergent Powder, Pesticides Etc.** in Four Head Weigh Filler

Technical Specification

Packing Range	: (50gm to 1Kg) (1kg – 5kg)	Speed	: 10 to 30 bag/min depend on the nature of the product
Filling System	: Four head Weigh Filler	Power	: 5 KW
Type of Sealing	: Center Seal	Optional	: Batch Coding Device, Batch Cutting Device, Z Elevator
Film Size	: 250mm- 600mm width x 100mm-450mm Length	Wooden Case	: 2500mm x 1200mm x 1200mm (H x W x L)
Film Roll Size	: OD 250 to 400mm max. ID film Reel Pipe 75mm	Machine Size	: 2800mm x 1700mmx 1400mm (L x W x H)
Film Roll Type	: Laminated Film	Machine Weight	: 850kg. (Approx)

NEXUS-500

Pneumatic Bagger with Two Head Weigher



Automatic Form Fill & Seal Machine with Two Head Weigh Filler for Grains & Free Flow Powder Products Like **Pulses, Rice, Tea, Sugar, Namkeen, Whole Spices, Detergent Powder, Pesticides Etc.** in Two Head Weigh Filler

Technical Specification

Packing Range	: 50gm to 1Kg	Speed	: 8 to 14 Pouches per minute depend on the product nature
Filling System	: Two Head Weigh Filler	Machine Weight	: 750kg. (Approx)
Type of Sealing	: Center Seal	Power	: 4KW Three Phase
Film Size	: 200mm-520mm width x 120mm-360mm Length	Optional	: Batch Coding Device, Batch Cutting Device, Z Elevator
Film Roll Size	: OD 250 to 300mm max. ID Film Reel Pipe 75mm	Wooden Case	: 2300mm x 1100mm x 1200mm (H x W x L)
Film Roll Type	: Laminated Film	Machine Size	: 2600mm x 1600mmx 1300mm (L x W x H)

NEXUS-SMART

Semi Pneumatic Cup Filler



Automatic Form Fill & Seal Machine with Cup Filler for Grains & Free Flow Powder items Like **Rawa, Broken Wheat, Detergent, Tea, Coffee, Namkeen, Puffs, Pesticides Etc.** in Volumetric Cup Filler

Technical Specification

Filling System	: Volumetric Cup Filler	PLC	: Delta
Filling Accuracy	: +/-0.1% - +/-0.2%	TC	: Selectron
Sealing Type	: Center Seal / 3 Side Seal	Contact Part	: SS 304
Filling Range	: 10gm to100 / 100gm to 250gm	Power	: 2.5 Kw
Film Role Material	: Laminated Film	Optional	: Batch Coding Device, Batch Cutting Device Gas Flushing Unit
Speed Capacity	: 25 to 40 Bag/min (Varies with the Nature of Product & Filling Range)	Machine Weight	: 450kg (Approx)
Machine Size	: 1050mm x 990mm x 1900mm (L x W x H)		

NEXUS-100

Collar Type Fully Pneumatic Cup Filler



Automatic Collar Type Form Fill & Seal Machine with Cup Filler for Grains & Free Flow Powder items Like **Rawa, Broken Wheat, Detergent, Tea, Coffee, Namkeen, Fryms, Peanut, Puffs, Soya Chunk, Pesticides Etc.** in Volumetric Cup Filler

Technical Specification

Packing Range	: 1. (20gm to100gm) 2. (100gm to 500gm) 3. (500gm to 1000gm)	Film Roll Type	: Laminated Film
Filling System	: Volumetric Cup Filler	Speed	: 40 to 60 bag/min (Varies with the nature of product & Filling range)
Type of Sealing	: Center Seal	Power	: 3 KW 230V / AC / Single Phase/ 50hz
Packing Material	: Powder, Grains, Etc	Optional	: Batch Coding Device, Batch Cutting Device Gas Flushing
Film Size	: 200mm-420mm width x 100mm-550mm length	Wooden Case	: 1700mm x 1000mm x 1100mm (H x W x L)
Film Roll Size	: OD 250 to 400mm max. ID film reel pipe 75mm	Machine Size	: 1050mm x 990mm 2100(L x W x H)
		Machine Weight	: 750kg. (Approx)

NEXUS-SMART

Semi Pneumatic Servo Auger Filler



Automatic Semi Pneumatic Form Fill & Seal Machine with Servo Auger Filler for Sticky Powder Products Like **Spices, Wheat Flour, Coffee Powder, Henna, Pesticides Etc.** in Servo Auger Filler

Technical Specification

Filling System	: Servo Auger Filling	Wooden Case	: 2650mm x 1000mm x 1000mm (H x W x L)
Filling Accuracy	: +/- 1 to 2% Depend upon nature of product	PLC	: Delta / Fuji
Sealing Type	: Center Seal / 3 Side Seal	Contact Part	: SS 304
Filling Range	: 50gm to 500gm	Filling System	: Servo Auger Filler
Packing Material	: Sticky Powder	Power	: 220v Ac Single Phase And Three Phase
Size of Bag/ Pouch	: W-100 to 360mm L-80 to 130mm	Optional	: Batch Coding Device, Screw Conveyor
Machine Size	: 2500mm x 800mm x 900mm (H x W x L)	Machine Weight	: 650kg (Approx)



NEXUS-1000

Collar Type Servo Bagger With Servo Auger Filler



Automatic Form Fill & Seal Machine with Servo Auger Filler for Sticky Powder Products Like **Spices, Wheat Flour, Gram Flour, Milk Powder, Ice Cream Powder, Pesticides Etc.** in Servo Auger Filler

Technical Specification

Packing Range	: 1. (100gm to 500gm) 2. (500gm to 1000gm)	PLC	: Delta / Fuji
Filling System	: Servo Auger Filler	Speed	: 40 to 60 PPM Depend On The Product Nature & Weight
Type of Sealing	: Center Seal	Power	: 5 KW Three Phase
Film Size	: 180mm-520mm width x 100mm-360mm Length	Optional	: Batch Coding Device, Batch Cutting Device, Screw Conveyor
Film Roll Size	: OD 250 to 300mm max. ID Film Reel Pipe 75mm	Wooden Case	: H 2200 mm, W 1000mm, L 1200mm
Film Roll Type	: Laminated Film	Machine Weight	: 750kg. (Approx)

NEXUS-100 HIGH SPEED

Pneumatic Bagger with Servo Auger Filler (High Speed)



Automatic Form Fill & Seal Machine with Servo Auger Filler for Sticky Powder Products Like **Spices, Gram Flour, Milk Powder, Ice Cream Powder, Pharmaceutical Powder, Pesticides Etc.** in Servo Auger Filler

Technical Specification

Packing Range	: 5gm to 50gm	Speed	: 60 to 90 Pouches Per Minute Depend On The Product Nature
Filling System	: Servo Auger Filler	Power	: 5KW Three Phase
Type of Sealing	: Center Seal	Optional	: Batch Coding Device, Batch Cutting Device, Screw Conveyor
Film Size	: 120mm-250mm width x 80mm-200mm Length	Wooden Case	: H 2200 mm, W 1000mm, L 1200mm
Film Roll Size	: OD 250 to 300mm max. ID Film Reel Pipe 75mm	Machine Weight	: 650kg. (Approx)
Film Roll Type	: Laminated film		

NEXUS-MECH

Mechanical F.F.S. Machine Cup Filler



Automatic Form Fill and Sealing Machine for Filling Dry, Free Flowing Products Like **Detergent Powders, Sugar, Salt, Tea Dust, Bhujia, Whole Spice, Chemical Etc.**

Technical Specification

Capacity	: 5gm to 20gm	Speed Capacity	: 35 to 60 Pouch per minute
Filling System	: Cup Filler	Contact Part	: SS 304
Filling Accuracy	: +/- 0.1 %	Dimension	: 780 x 650 x 1950mm (LxWxH)
Sealing Type	: Center Seal / 4 Side Seal, 3 Side Seal	Power	: 2kw Single Phase
Packing Material	: Laminated Film	Optional	: Batch Coding Device
Film Size	: 160mm-250mm Width 140mm-200mm Length	Machine Weight	: 450kg (Approx)

NEXUS-MECH

Mechanical F.F.S. Machine Piston Filler



Automatic Form Fill & Seal Machine for Free Flowing Liquid and Semi Liquid to Pack Products Like **Shampoo, Honey, Coconut Oil, Tomato Puree, Oil, Grease, Paste** and any other Free Flowing Materials in Piston Filler

Technical Specification

Packing Rang	: 1. (2ml to 20ml) 2. (20ml to 50ml) 3. (50ml to 100ml)	Speed Capacity	: 35 to 50 Pouch per minute
Filling System	: Volumetric Piston Filing	Machine Size	: 780 x 650 x 1950mm (LxWxH)
Filling Accuracy	: +/- 0.1 %	Contact Part	: SS 304
Sealing Type	: Center Seal / 4 Side Seal, 3 Side Seal	Power	: 2kw Single Phase
Filling Range	: Up to 100ml	Optional	: Batch Coding Device
Packing Material	: Liquid & Semi Liquid	Machine Weight	: 430kg (Approx)

NEXUS-MULTI

Multi Track Packing Machine



Automatic Multi-Track Form Fill & Seal Machine with Piston Filler for Liquid and Semi Liquid Products Like **Shampoo, Ketchup, Oil, Cream, Pharma products & Pesticide products**

Technical Specification

Packing Range	: 2ml to 50ml (2gm to 50gm)	Speed	: 50 to 100 Stock Per Minute (Varies with the nature of product & Filling range)
Filling System	: Piston Filler, Cup Filler	Power	: 4 KW 440V / AC / Three Phase
Sealing Type	: Four Side Seal	Optional	: Batch Coding Device, Batch Cutting Device Auto Lubrication, GMP Model, Gas Flushing Unit Level Sensor
Packing Material	: Laminated Film	Machine Size	: 2200mm x1700mm x 2300mm
Film Size	: 400mm-900mm width x 50mm-150mm length	Machine Weight	: 1500kg (Approx)
Film Roll Size	: OD 250 to 400mm max. ID film reel pipe 75mm min		
Film Roll Type	: Laminated Film		

NEXUS-ROTARY

Automatic Rotary Pouch Packing Machine

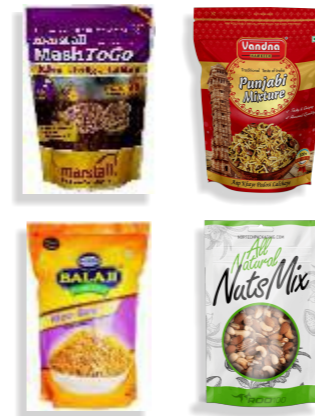

The Granules packing machine is suitable for granule material, such as **Melon seeds, Nuts, Candy, Raisins, Chinese Wolfberry, Red dates, Potato chips, Cookies** and other solid material automatic packing.

Technical Specification

Bag material	: Laminated film/PE/PP	Voltage	: 380v 3phase 50/60hz
Bag pattern	: Stand-up with zipper & stand-up with spout, flat bag,	Total power	: 5.5KW
Max filling weight	: 10-5000ml	Compress air	: 0.6m ³ /min
Filling accuracy	: 0.5-1%	Detecting device	: 1.No ribbon, alarm and Emergency stop 2.No pouch or pouch open error, no filling, no sealing
Bag size	: Type 1 W:100-200mm L:100-350mm Type 2 W:150-260mm L:100-350mm Type 3 W:200-300mm L:200-450mm	Safety device	: 1.Open the door, alarm a Emergency stop(Optional) 2.The air pressure not enough, alarm 3.the sealing temperature anomaly, alarm
Speed	: 10-60bags/min		

NEXUS-HFFS SMART

Mechanical Horizontal Flow Wrap Machine



Automatic Horizontal Flow Wrap Machine with Manual Feeding for Packing solid products like **Chocolate, Biscuit, Lollypop, Soap, Peanut Candy, Ice Candy, Scrub Pad, Auto Parts, Industrial Parts, any solid piece Etc.**

Technical Specification

Filling System	: Automatic/ Manual	Power	: Motor 1.5 HP DC with DC drive
Type of Sealing	: Center Seal (Pillow Type)		: 220V / single Phase, Load -3kw
Packing Material	: Chocolate, Biscuit Etc.	Machine Size	: 1080mm x 1700mm x
Film Roll Type	: Laminated film in roll supported film		: 1800(approx..)
	E.g.. Aluminum Foil Pe, PP	Machine Weight	: 700kg (Approx)
Speed	: Approx 40 to 120 pouches/ min(Depend upon the Packet size)		

NEXUS-HFFS

Horizontal Flow Wrap Machine (High Speed)



Automatic Horizontal Flow Wrap Machine with Manual Feeding for Packing solid products like **Chocolate, Biscuit, Lollypop, Soap, Peanut Candy, Ice Candy, Scrub Pad, Auto Parts, Industrial Parts, any solid piece Etc.**

Technical Specification

Model	HFFS 250	HFFS 320	HFFS 450
Max Film Width	250mm	320mm	450mm
Bag Length	65mm - 190mm	120mm-280mm	65mm-190mm
	120mm – 280mm	130mm-450mm	
Bag Width	30mm-110mm	50mm-160mm	60mm-220mm
Max Product Height	40mm	40mm	80mm
	55mm	55mm	
Speed	40-230 PPM	40-230 PPM	30-180 PPM
Power	MOTOR 1 H.P	MOTOR 1 H.P	MOTOR 1 H.P
	2.5KW SINGLE PHASE	2.5KW SINGLE PHASE	2.5KW SINGLE PHASE
Machine Size	1800mm L	1800mm L	1800mm L
	1000mm W	1000mm W	1000mm W
	1360mm H	1360mm H	1360mm H
Machine Weight	700kg (Appx.)	800 (Appx.)	900(Appx.)

Filler & Accessories



10 Heads Weigher



20 Heads Weigher
with double outlet



14 Heads Weigher

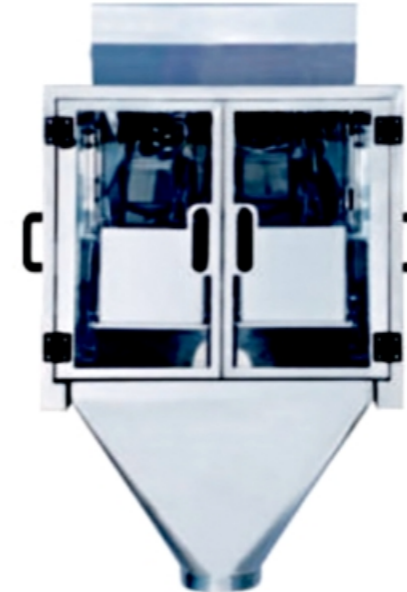

2 Heads
lomear weogjer



4 Heads linear Weigher



500g Aiger
screw filler



5000g Auger
screw filler

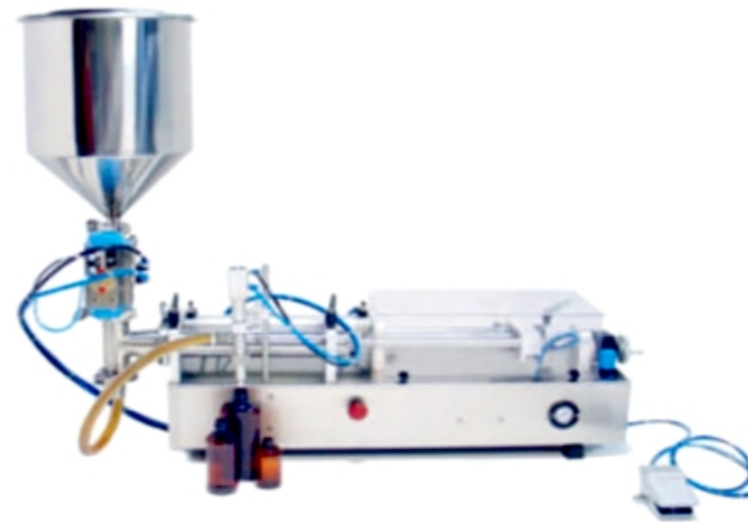

Pneumatic Piston
Filler



Lobe Pump
Filler For Past

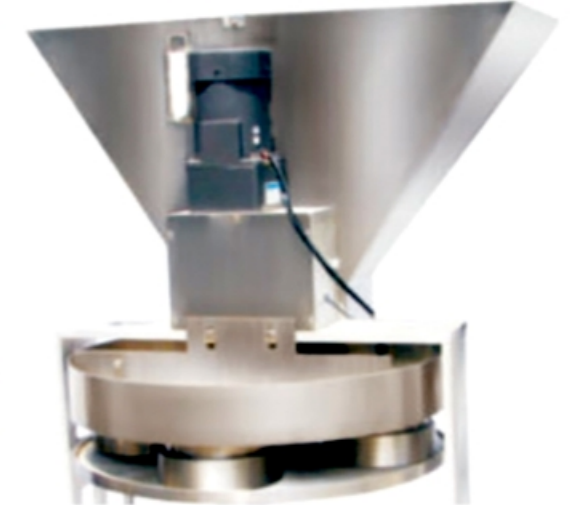

Rotary volumetric
cup filler

CONVEYORS

Takeaway Conveyor



Bucket Elevator



Inclined Conveyor



Automatic Case Indexing & Filling Equipment

